

# MOTOR/CLUTCH ASSEMBLY

Figure 4

1. BGFM12 MOTOR
2. TT1X CLUTCH
3. 10176 MOTOR PLATE

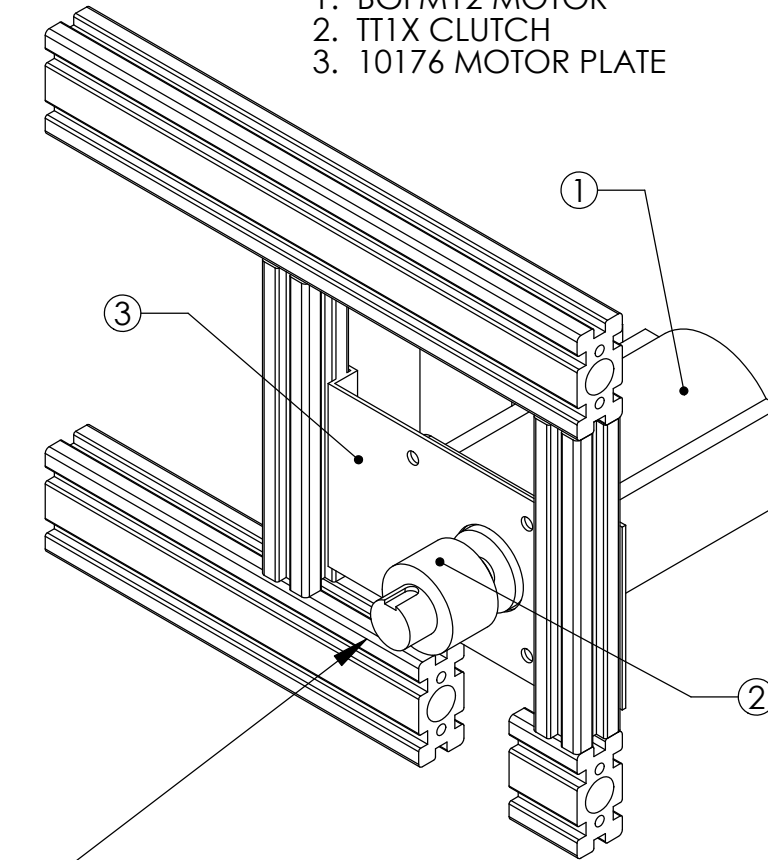

TO REMOVE CLUTCH FROM MOTOR SHAFT,  
LOOSEN (2) SETSCREWS WITH 3/32" ALLEN  
WRENCH FROM BOTTOM SIDE. ONE SETSCREW  
IS MATED WITH SHAFT FLAT.